



ARM Based Wireless Sensor Network for Temperature Measurement

Meraj Mohd Khan

Dept. of Electronic and Communication Engg
Nawab Shah Alam Khan College of Engg & Tech
Hyderabad, India
merajmohdkhan@gmail.com

Md Osman Ali Naveed

Dept. of Electronic and Communication Engg
Nawab Shah Alam Khan College of Eng & Tech
Hyderabad, India
mdosmanali6070@gmail.com

Abstract— with the development of the science and technology, there is a huge improvement in the field of automobiles, which emphasize to provide the safety measurements especially to the difficulties due to abnormal temperatures of some key points in vehicle. But it is difficult to link too many points to the controlling device through electric wires because of the fabrication issues. There is a possible solution to overcome these problems through developing a WSN for a temperature measurement system. Here the temperature signals are acquired by sensors and transmitted to the advanced RISC microprocessor (ARM) by using Wireless Fidelity (Wi-Fi) technology, which is proved for transferring data accurately without fail and then data is stored in SD card which is controlled by the microprocessor according to the IIS-bus standard format. The functionality is developed by ARM 9 based Samsung S3C2440 Controller with transplantation of Linux operating system on it. The flow of operation is described, included along with the driver programs of SD card and Wi-Fi device.

Index Terms— ARM 9; Temperature Sensor; Wi-Fi (802.11b/g); Linux.

I. INTRODUCTION

In order to ensure the safety of the system we need several measures one of which is temperature monitoring of some key points in vehicles, including the fuel tank, the engine and the speed changer, etc. However, it is difficult to link too many points to the processor through electric wires, and the classical isolated sensors have some disadvantages of slow reaction rate, high measuring errors, complex installation and so on.

There is a possible solution to overcome these problems through developing a WSN for temperature measurement system. A WSN is a wireless network consisting of many sensor nodes and a control terminal. It could detect and collect a variety of environmental or object information in the network coverage area, and process the information effectively.

As the core module of the temperature measurement system, the embedded microprocessor Samsung S3C2440, is used. It is a 32-bit, 400MHz, low power consumption and high performance RISC microprocessor with ARM 9 as its kernel, which is particularly suitable for real-time control. Moreover, it supplies SD Wi-Fi device, so there is no need of collocating excess wireless equipment any more.

Besides, the embedded Linux operating system is selected to support the hardware. It is a kind of mature open-source operating system, which is encapsulated in ARM, to accomplish complex algorithms and finish a variety of tasks. Besides, depending on the specific-application, the software system could be also tailored to adapt the requirements

This paper firstly presents the fundamental theory of Wi-Fi based wireless transmission and then introduces the system hardware design, including the system structure, 4 hardware modules and corresponding functions.

II. RELATED WORK

According to module design discipline, the WSN for the temperature measurement system consists of system core module, data acquisition and transmission module, data storage module and man-machine interaction module.

A. SYSTEM CORE MODULE

The system core module includes core microprocessor, NAND Flash and SDRAM. The core microprocessor adopts the ARM (PC) as its CPU, whose configuration is shown in Fig.1. It supports operating systems Linux SDRAM is used for storing program code, and NANDFLASH is used to save the startup code and the file system. The ARM supplies abundant equipments inside to bring down the cost of the whole system and there is no need of collocating excess equipments any more. The buses inside the ARM 9 are all high performance ones designed with larger bandwidth. The functions of integrated circuit include: separate 16KB instruction Cache and 16KB data Cache, MMU virtual memory management, LCD controller, supporting NAND Flash system induction, outside memory controller, 3- channels UART, 4-channels DMA, 4-channels PWM timer, 117 currency I/O interface, 24-channels outer interrupt recourse, RTC with calendar, 8-channels 10bit ADC and touch screen interface, IIC-bus interface, IIS-bus interface, USB mainframe, USB equipment, 2-channels SPI, and interior PLL clock times frequent count. The peripheral equipments inside of the chip are connected with the bus inside of the chip as well.

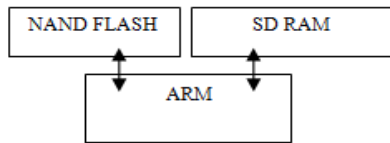

Fig. 1 The configuration of the system core module

B. DATA ACQUISITION AND TRANSMISSION MODULE

In the WSN designed, the data acquisition and transmission module is a sensor node in fact. As the core of the entire module, the PC plays the control role. Both the Digital Thermometer and the wireless Wi-Fi transmitter are linked to it. The Configuration of data acquisition and transmission module is shown in Fig. 2.

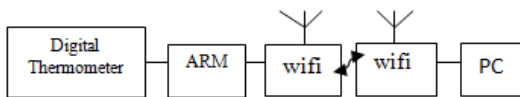

Fig. 2 The configuration of data acquisition and transmission module

1) DATA ACQUISITION UNIT:

The acquisition of temperature signals is realized by the digital thermometer, which is a 1-wire digital thermometer HSM20G. Comparing with the traditional temperature sensors, this has many advantages, mainly including digital counting, direct output of the measured temperature signals in digital form, less temperature error, high resolution, strong anti-interference ability. It has an operating temperature range of -55°C to $+125^{\circ}\text{C}$ and is accurate to $\pm 0.5^{\circ}\text{C}$ over the range of -10°C to $+85^{\circ}\text{C}$. There are two power supply ways for the digital thermometer: the external power supply and the parasite power supply. The parasite power supply will lead to the complexity of the hardware circuit, the difficulty of the software control and the performance degradation of the chip, so the external power supply is selected. This way is accomplished through connecting the digital thermometer to the I/O port of the Microcontroller directly. As shown in Fig. 3, the first pin of the thermometer is connected to the ground; the second pin serves as signal wire and is directly connected to P0.3 of the PC; the third pin is used for external power supply.

$R1$ is a pull-up resistor. After temperature signals are acquired by the digital thermometer, they are converted into digital ones and stored in the PC temporarily

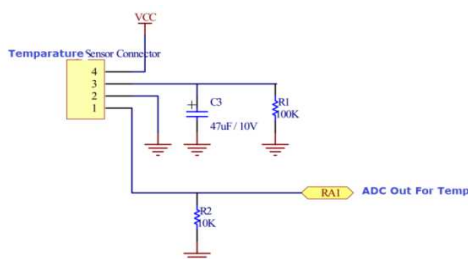

Fig.3 The Interface Block Diagram Of HSM20G

2) DATA TRANSMISSION UNIT:

In the WSN, the data in the ARM9 is transmitted to the PC by the Wi-Fi-based wireless means. Wi-Fi-based wireless technology has some outstanding advantages: the broader coverage, the lower cost, the ability of facilitating the up-grad, etc. It can work in the bandwidth of near 2.4 GHz which do not need any permission for use. Its maximum communication rate can reach 11 Mb/s, the transmission radius reaches 300 m outdoor and 100 m indoor. All Wi-Fi devices in such WSN are separated into two kinds according to the usage: one is used as the receiver and the others are all the transmitters. The receiver has been integrated on the development board and each of the transmitters is connected to the corresponding single-chip through linking its USB of the single-chip. The interface block diagram of Wi-Fi transmitter is shown in Fig. 4. Temperature data stored in the single-chips temporarily are sent into the transmitters, and then transmitted out.

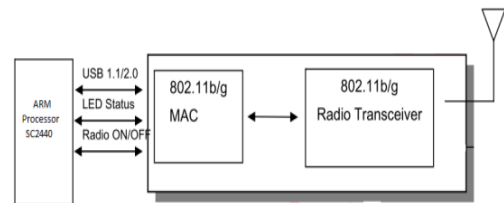

Fig. 4 The interface block diagram of Wi-Fi transmitter

3) WIRELESS COMMUNICATION STANDARDS:

Wi-Fi-based wireless communication belongs to the short-range wireless technology, whose current communication standards include: IEEE 802.11a, IEEE 802.11b, IEEE 802.11g and IEEE 802.11n, etc. The widely-used one in them is IEEE 802.11b, which can provide the credible data transmission and reasonable network bandwidth by using the protocol and the packet acknowledgement linking Ethernet. Therefore, IEEE 802.11b standard is selected in this Wireless Sensor Network.

C. DATA STORAGE MODULE

After the audio signals are received, SD card is selected to store them. The storage technology of SD card is the de facto industry standard for consumer electronic devices. SD cards are used in standard and high - capacity formats along with a variety of speed classes. SD card has four data wire interfaces (DATA0:3), one clock wire interface (CLK) and one command wire interface (CMD), they are all linked to the PC. SD card supports 1-wire and 4-wire reading/writing operating modes [13]. When 1-wire operating mode is supported, DATA0 is used for serial data transmission, DATA1 works as an interrupt interface, the highest rate of transmission reaches 25Mbps. When 4-wire operating mode is supported, DATA0:3 are all used for serial data transmission, the highest rate of transmission is 100 Mbps.

D. MAN-MACHINE INTERACTION MODULE

In order to realize the function of man-machine interaction, it is necessary to display temperature information through screen. In the system, is linked to the ARM9.

III. SYSTEM IMPLEMENTATION & RESULTS

In order to acquire temperatures of many points, a variety of sensor nodes are designed and placed at corresponding positions. Each sensor node consists of a single-chip ARM9, a digital thermometer HSM20G and a Wi-Fi transmitter. Temperature signals are acquired by the digital thermometer, then sent by wireless means, and transported to the ARM for processing. All above constitutes a WSN, which allows users to fully grasp temperature information in the region to monitor and respond to them. The network architecture of the system is shown in Fig. 5.

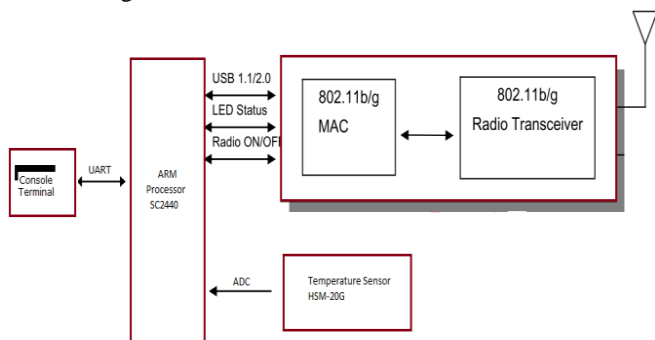

Wireless Sensor Network for an Intelligent Measurement System Based on ARM

The algorithm is as follows

- **Step1:** Initialize the Boot device
- **Step2:** Read data from HSM 20G if yes go to step 3 if not go to step 1
- **Step3:** Initialized the ADC module with different channel inputs
- **Step4:** Digital signal is sent to ARM
- **Step5:** If Console terminal data is sent then go to next step if not go to step 5
- **Step6:** Acquired data is transmitted to Mac 802.11b/g from arm
- **Step7:** If led is on data is transmitted, if led is off then move to step 7
- **Step8:** Data is transferred through transceiver
- **Step9:** Finally stop execution.

IV. CONCLUSION

In this paper, a WSN is used for temperature measurement system and the hardware and Software architectures are described in detail. In the system Wi-Fi based wireless communication technology is used. It has outstanding advantages, including broader coverage (10000_ m² indoor and 90000_ m² outdoor) and higher transmission rate (11Mbps). All the data wire interfaces (DATA0:3) of SD card can be used

for serial data transmission, the highest rate of transmission reaches 100Mbps. The system fully makes advantage of SD card's characteristic of huge and long- time storage, remedying the defect of Nor Flash's small storage in ARM. Long-distance control is accomplished the huge data stored in SD card can be transferred to the control center.

REFERENCES

- [1]. Qingdong Wang and Jianfeng Wei, "Design of Temperature Control Device Underground Coal Mine Based on AT89S52.
- [2]. Muzaiyanah Hidayab, Abdul Halim Ali and Khairul Bariah Abas Azmi, "Wifi Signal Propagation at 2.4 GHz," The 2009 IEEE, pp.528-531.
- [3]. T.S. Rappaport "Wireless communications principles and practices," Prentice-Hall, 2002
- [4]. Shouqian YuWeihai ChenLi Li, and Jianglei Qin, "Development of ARM -based Embedded System for Robot Applications," 2006 ICEMT, 2006, pp.101-105.
- [5]. <http://www.friendlyarm.net/products/mini2440>
- [6]. [http://www.thaieasyelec.net/index.php/SBC Embedded - OS/mini2440-TFT-3-5-inch-Touch-Screen](http://www.thaieasyelec.net/index.php/SBC%20Embedded%20OS/mini2440-TFT-3-5-inch-Touch-Screen)
- [7]. S3C2440-ARM9-Development-Board-256-MB-NAND-FLASH- /p_53.html