

# Use of Smart Sensors to Improve Reliability of an Embedded Surveillance System

Rohit Ratnakar Vaidya

Department of Electronics & communication Engineering  
Deogiri Institute of Engineering and Management Studies,  
Aurangabad (MS), India  
Vaidyarohit007@gmail.com

**Abstract**— In this paper we have to design and implement surveillance system by use of smart sensors like ultrasonic sensors and pyroelectric infrared sensors (PIR) to detect an intruder in a home, ATM, Industries, Bank Locker room or a storehouse. The PIR sensors are placed on the ceiling, and the ultrasonic sensor module consists of a transmitter and a receiver which are placed vertically on the wall. We are going to use the camera to capture images of the people those are coming under the surveillance area. And we are sending these images to authorized and related personnel via e-mail to avoid the storage cost. This system will also help to reduce the power consumption.

**Keywords**—Raspberry Pi; Embedded Surveillance System; Smart Sensors ; Camera; Internet.

## I. INTRODUCTION

Recently surveillance systems have become more important for everyone's and everywhere for the purpose of security. The embedded surveillance system, frequently used in a home, an office or a factory [1-3], uses a sensor triggered to turn on a camera [4-5]. Some designs use different types of sensors to achieve reliability by means of the different features of each sensor [6-7] but they do not provide any facilities like sending an image through internet. In this paper we have to extend this previous system not only by using both multiple PIR sensors and ultrasonic sensors as a sensor group, but also by using the Maximum Voting Mechanism (MVM) [8-11]. Ultrasonic receivers and transmitters are located at opposite ends to reduce the interference from other frequencies in ultrasonic signals. Some research explores the influence of attenuation in air and crosstalk of ultrasonic signals. In our system, We have to use Raspberry Pi credit card-sized computer to send an Email of captured image to the specified Email ID. So that there is no issue of storing images as well no issue of losing the confidential data (captured images).

## II. SYSTEM ARCHITECTURE

As shown in Fig. 1 our system which contains several groups of ultrasonic and PIR sensor. The transmitter circuit generates a multi-frequency square waveform, and the receiver circuit amplifies the received signals and filters out any noise. When a transmitter transmits an ultrasonic coding signal, the ultrasonic receiver determines whether there is an intruder or person passing through the sensing area. If there is no

intruder, the MCU (Micro Controller Unit) will keep our camera off but as soon as intruder is detected and camera can capture the image. Our design reduces the environmental interference with the ultrasonic signal. All sensing signals are input to the embedded surveillance system by the GPIO (General purpose input and output), and the MVM program counts the number of sensing states to determine whether to adopt the MVM or not. The PIR sensor groups obtain the sensing signals from human temperature. If the voting results of ultrasonic and PIR sensor groups pass the criteria, the embedded surveillance system starts the camera to capture images. When it capture the image this image is send to the specified Email ID via Internet.

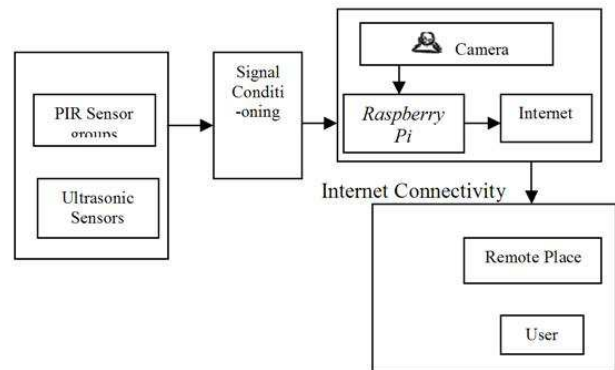

Figure 1. Use of smart sensors to improve the sensing reliability of an embedded surveillance system

### A. Software Required

We choose Embedded Linux as our operating system. The program of the majority voting mechanism contains a detection of the GPIO function, a counting and majority voting function, an image captured function and a Web server. Fig.3.2 shows the detection software flowchart of the embedded system. The embedded system scans the GPIO sockets, which are connected to external PIR sensors and ultrasonic sensors. To verify the state of each IR and ultrasonic sensor, the embedded system reads the voltage levels of the GPIO sockets. When the system reads 5V from a GPIO socket, we learn that the ultrasonic sensors or the PIR sensors have been triggered and will execute the majority

voting program by counting the state of each ultrasonic and PIR sensor. Majority voting is achieved by the sensor groups of the different GPIO sockets. The embedded system, when interrupted by the detection procedure, starts the Web camera to capture images. When this is finished, the embedded system starts the detection procedure over again. If the intruder is still in the monitoring area, the count of the GPIO sockets' voltage levels continues the majority voting mechanism, and the embedded system again starts the Web camera to capture images. The embedded system uploads the captured images by means of both the Web server and the streaming server through the Internet.

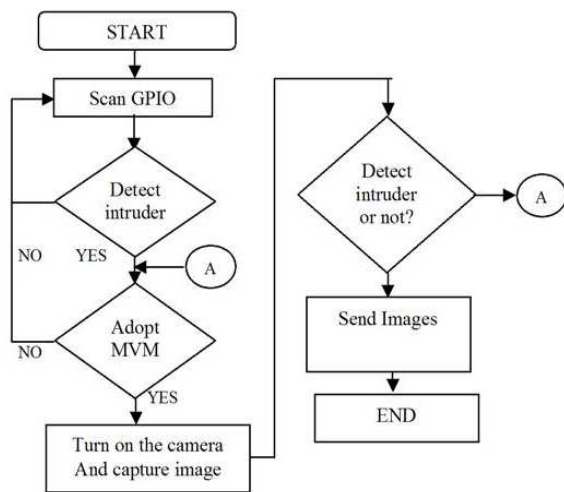

Figure 2. Detection software flowchart

### B. Hardware modules

We use two groups of the external hardware circuits, the PIR and the ultrasonic sensor group. As the PIR sensor produces a weak voltage, we input the sensed signal to a two-stage OP amplifier to amplify the weak voltage by about 1000 times. Since the amplified signal changes between positive

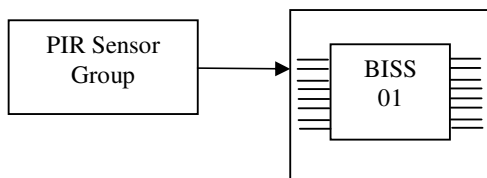

Figure 3. PIR module.

and negative voltage, we input this signal to the absolute value circuit, and then we input it to the adjustable comparator to and negative voltage, we input this signal to the absolute value circuit, and then we input it to the adjustable comparator to compare the sensing voltage and the reference voltage which are set according to the environment temperature. Fig. 3 shows the block diagram of the PIR module. Compact and complete, easy to use Pyroelectric Infrared (PIR) Sensor Module for

human body detection. Incorporating a Fresnel lens and motion detection circuit. High sensitivity and low noise. Output is a standard 5V active low output signal.

Fig. 4 shows the ultrasonic circuit which uses a pulse width modulation (PWM) function in the MCU to send out the desired frequency of the ultrasonic signal. The ultrasonic transducer transforms the voltage waveform into an ultrasonic transmission, and the transducer of the receiver transforms the ultrasonic transmission into the voltage waveform. The ultrasonic sensor can easily be interfaced to microcontrollers where the triggering and measurement can be done using two I/O pin. The sensor transmits an ultrasonic wave and produces an output pulse that corresponds to the time required for the burst echo to return to the sensor. By measuring the echo pulse width, the distance to target can easily be calculated.

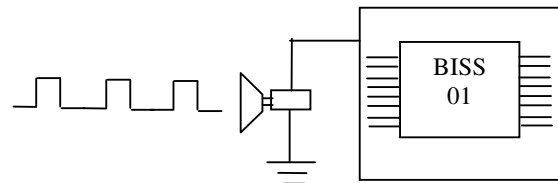

Figure 4. Ultrasonic Sensor with Controller

Table I shows our comparison of the sensing characteristics of both the ultrasonic sensor and the PIR sensor [6]. We have found that the ultrasonic sensor and the PIR sensor can both compensate each other and enhance the overall sensing probability in our design.

TABLE I. COMPARISON OF CHARACTERISTICS OF PIR SENSOR AND ULTRASONIC SENSOR

Sensors	Condition For trigger	Effect of Environment temperature	Sensing Type
Ultrasonic	Moving block	Independence	Line direction
PIR	Temperature change	Dependence	Projection area

### Why Raspberry Pi? □□□□□□ □□□ □□□

➤ The Raspberry Pi is a credit-card-sized single-board computer developed in the UK. The Raspberry Pi has a Broadcom BCM2835 system on a ip (SoC), which includes an ARM1176JZF- 700 MHz processor, Video Core IV GPU, and was originally shipped with 256 megabytes of RAM, later upgraded to 512 MB. It does not include a built-in hard

disk or solid-state drive, but uses an SD card for booting and persistent storage

- The Processor. At the heart of the Raspberry Pi is the same processor you would have found in the iPhone 3G and the Kindle 2, so you can think of the capabilities of the Raspberry Pi as comparable to those powerful little devices. This chip is a 32 bit, 700 MHz System on a Chip, which is built on the ARM11 architecture. ARM chips come in a variety of architectures with different cores configured to provide different capabilities at different price points. The Model B has 512MB of RAM and the Model A has 256 MB.
- The Secure Digital (SD) Card slot. You'll notice there's no hard drive on the Pi; everything is stored on an SD Card. One reason you'll want some sort of protective case sooner than later is that the solder joints on the SD socket may fail if the SD card is accidentally bent.
- The USB port. On the Model B there are two USB 2.0 ports, but only one on the Model A. Some of the early Raspberry Pi boards were limited in the amount of current that they could provide. Some USB devices can draw up 500mA. The original Pi board supported 100mA or so, but the newer revisions are up to the full USB 2.0 spec.

Fig. 5 shows our design which consists of the internal software and the home embedded system software module. When an intruder has been detected, the MCU wakes up the majority decision to test the threshold and then turns on the power supply for the indoor sensors. If the indoor sensors detect no intruder when the outdoor sensors are misjudging, the MCU turns off the power of the indoor sensors and goes back to the alert state. If the indoor sensors detect an intruder, the MCU turns on the camera to capture images in keeping with the decision of the MVM.

### III. ARRANGEMENT

Arrangement of our experimental environment that detect intruders in a suitable place. We place the PIR sensor on the ceiling or above the detection area. Transmitter and receiver of the ultrasonic sensor module are placed in a line direction. When an intruder enters the detection area, the ultrasonic coding signal will be blocked and the PIR sensors will detect temperature changes.

### IV. CONCLUSION

This system shows two different types of sensors which are Improving the overall sensing probability by using the MVM to reduce the shortcomings of both the ultrasonic sensors and the PIR sensors. As well as we are providing the facility of sending live images to certain (Authorized) person via EMAIL. In future may be we are also able to send some videos (clips).

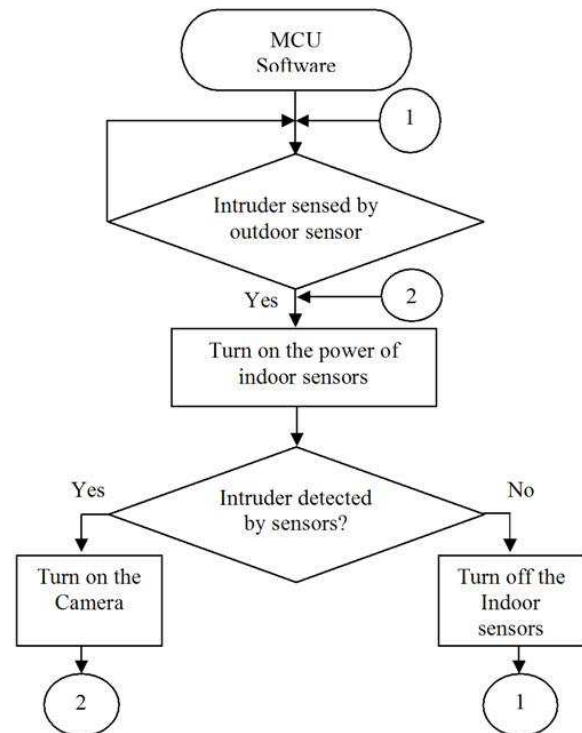

Figure 5. Software flowchart

### REFERENCES

- [1]. Jun Hou, Chengdong Wu, Zhongjia Yuan, Jiyuan Tan, Qiaoqiao Wang and Yun Zhou, "Research of Intelligent Home Security Surveillance System Based on ZigBee," International Symposium on Intelligent Information Technology Application Workshops, Shanghai, 21-22 Dec. 2008, pp. 554-57.
- [2]. Xiangjun Zhu, Shaodong Ying and Le Ling, "Multimedia sensor networks design for smart home surveillance," Control and Decision Conference, 2008, Chinese, 2-4 July 2008, pp. 431-435.
- [3]. L. Lo Presti, M. La Cascia, "Real-Time Object Detection in Embedded Video Surveillance Systems," Ninth International Workshop on Image Analysis for Multimedia Interactive Services, 7-9 May 2008, pp. 151-154.
- [4]. Wen-Tsuen Chen, Po-Yu Chen, Wei-Shun Lee and Chi-Fu Huang, "Design and Implementation of a Real Time Video Surveillance System with Wireless Sensor Networks," VTC Spring 2008. IEEE Vehicular Technology Conference, 11-14 May 2008, pp. 218-222.
- [5]. Mikko Nieminen, Tomi Raty, and Mikko Lindholm, "Multi-Sensor Logical Decision Making in the Single Location Surveillance Point System," Fourth International Conference on Systems, France, 1-6 March 2009, pp. 86-90.



## **International Journal of Ethics in Engineering & Management Education**

**Website: [www.ijeee.in](http://www.ijeee.in) (ISSN: 2348-4748, Volume 5, Issue 9, September 2018)**

---

- [6]. Ying-Wen Bai, Li-Sih Shen and Zong-Han Li, "Design and Implementation of an Embedded Surveillance System by Use of Multiple Ultrasonic Sensors", The 28th IEEE International Conference on Consumer Electronics, Las Vegas, Nevada, USA, 11-13 Jan. 2010, 11.1-3, pp. 501-502.
- [7]. Yang Cao, Huijie Zhao, Na Li and Hong Wei "Land-Cover Classification by Airborne LIDAR Data Fused with Aerial Optical Images," International Workshop on Multi-Platform/Multi-Sensor Remote Sensing and Mapping (M2RSM), Jan. 2011, pp. 1-6.
- [8]. Hai-Wen Zhao, Hong Yue, and He-Gao Cai, "Design of a Distributed Ultrasonic Detecting System Based on Multiprocessor for Autonomous Mobile Robot," Proceedings of the 2007 WSEAS Int. Conference on Circuits, Systems, Signal and Telecommunications, Gold Coast, Australia, January 17-19, 2007, pp. 59-64.
- [9]. Zi-Li Xie and Zong-Han Li, "Design and implementation of a home embedded surveillance system with ultra-low alert power," IEEE Transactions on Consumer Electronics, Feb. 2011, pp. 153-159.
- [10]. Francesco Alonge, Marco Brancifortem and Francesco Motta, "A novel method of distance measurement based on pulse position modulation and synchronization of chaotic signals using ultrasonic radar systems," IEEE Transactions on Instrumentation and Measurement, Feb.2009, pp. 318-329.
- [11]. Shraga Shoal and Johann Borenstein, "Using Coded Signals to Benefit from Ultrasonic Sensor Crosstalk in Mobile Robot Obstacle Avoidance," IEEE International Conference on Robotics and Automation, Seoul, Korea, 21-26 May, 2001, vol.3, pp. 2879-2884.